



The **RAMJET TC-300 TANK®** is the third in the Trash Commander® Series of short, yet powerful stationary compactors. With crossed-cylinder technology, it is the most exciting development in the waste compaction industry. The \*3 cubic yard capacity compaction chamber is incorporated into a body that is only **9'-4 1/2" long!** This allows for greater throughput capacity in applications where space is limited such as retail outlets, department stores, malls, large restaurants, grocery stores and shopping centers.

The large 67 1/2"L x 58"W clear-top opening allows for large bulky items and greater throughput capacity. The TC-300 TANK is ideal for dock feed applications. With a 4-sided, rear feed hopper, there is no need for special walk-on tops or guard rails.

\*2.27 cy. WASTECC Rating and 3.0 cy. Mfg Rating

## The Trash Commander

# TANK®

*The Shortest 3 Cubic Yard Compactor in the Industry!*



The **TC-300 TANK** (foreground) compared to a standard 3 cy. compactor showing the difference in overall length – yet the clear-top opening of the TANK is the same as the larger RJ-325. The picture also illustrates that if the TANK is fitted with a 4-sided, rear feed hopper, there is no need for tread plates or guard rails.

# TC-300 3cy. TANK *The shortest 3 cy. compactor in the industry!*

Designed to meet applications where space is limited, but superior strength, dependability and compaction performance are a must!

## Specifications

Model: TC 300T-	HD	HDHF
Charge Box Capacity (Mfrs. Rating) . . . . .	3.0 cy . . . . .	3.0 cy
(WASTEC) Standards) . . . . .	2.27 cy . . . . .	2.27 cy
Clear Top Opening Width . . . . .	58" . . . . .	58"
Clear Top Opening Length . . . . .	67 1/2" . . . . .	67 1/2"

## Performance

Cycle Time . . . . .	77 sec . . . . .	59 sec
Total Normal Force . . . . .	54,500 Lbf . . . . .	62,700 Lbf
Normal Ram Face Pressure . . . . .	34.9 psi . . . . .	40.2 psi
Ram Penetration . . . . .	13.5" . . . . .	13.5"

## Hydraulics/Electronics

Remote Power Unit		
Motor . . . . .	10 hp . . . . .	15 hp
3/60/230-460		
Control Voltage . . . . .	120 VAC . . . . .	120 VAC
UL Label Panel Box; All Circuits Fused;		
Standard Controls: Keylock, Stop, Reverse		
Pump . . . . .	10 gpm . . . . .	13 gpm
Normal, psi . . . . .	2,000 psi . . . . .	2,300 psi
Cylinder Stroke (2), Inches . . . . .	55.25" . . . . .	55.25"
Cylinder Bore (2), Inches . . . . .	4.5" . . . . .	4.5"
Rod Diameter, Inches . . . . .	2.5" . . . . .	2.5"

<b>Weight</b> . . . . .	5,800 lbs . . . . .	5,800 lbs
-------------------------	---------------------	-----------

The TC-300 TANK features  
**Marathon's Signature  
Series Warranty:**  
3 years structure,  
2 years components  
and 6 months labor.

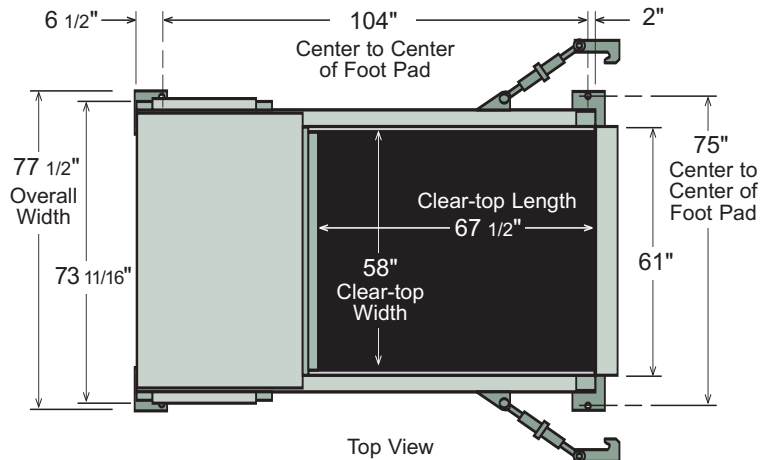
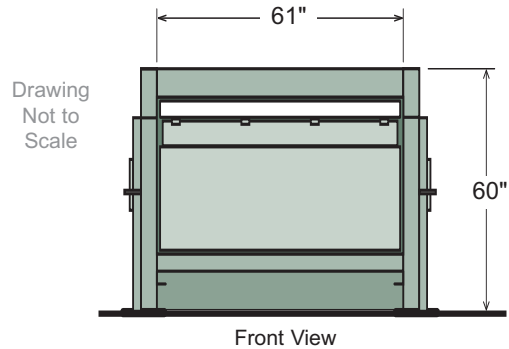
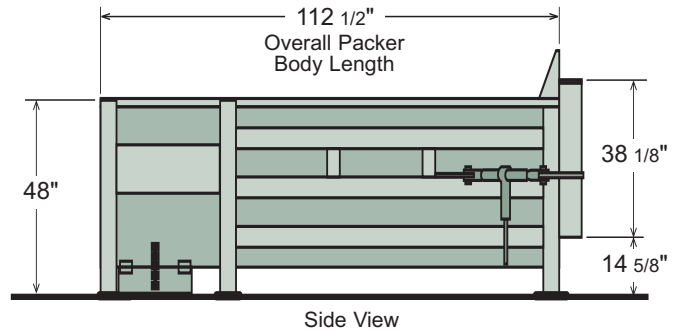

Authorized Distributor:

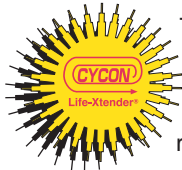

The TANK has Marathon's patented **CYCON Life-Xtender®** Cyclic Control System for reliable, solid state circuitry that eliminates all pressure and limit switches, extends the life of cylinders and hoses and assures maximum compaction ratios and performance.

Visit our web site: [www.MarathonEquipment.com](http://www.MarathonEquipment.com)



MARATHON EQUIPMENT COMPANY

P.O. Box 1798 • Vernon, AL 35592-1798 USA • (205) 695-9105 fax (205) 695-7250 **1-800-633-8974**

130 Hwy. 339 • Yerington, NV 89447 USA • (775) 463-4030 fax (775) 463-4531 **1-800-624-5724**

1102 Industrial Park Rd. • Clearfield, PA 16830 USA • (814) 765-0200 fax (814) 765-2072 **1-800-922-7062**

Pictures in this literature are illustrative only. Specifications are subject to change without notice in order to accommodate improvements to the equipment. Certified in compliance with ANSI Regulation Z245.2, all OSHA standards, and certified under WASTEC's Stationary Compactor Certification Program. Products must be used with safe practice and in accordance with said regulations and standards.

